

"TRADER" SERVICE SHEET  
633

# FERGUSON 801

## and 804 CONSOLE

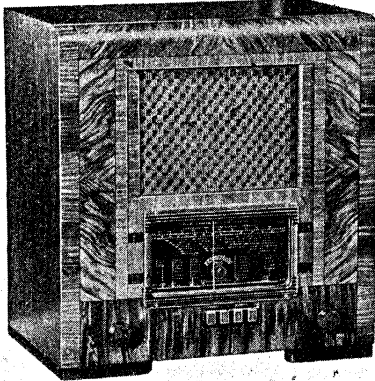

The Ferguson 801.

**P**RESS-BUTTONS are used in the Ferguson 801 receiver for waveband and gramophone switching, although tuning is performed manually, in the nor-

mal manner. The set is a 4-valve (plus rectifier), 3-band superhet, designed to operate from AC or DC mains of 200-250 V, 40-100 c/s in the case of AC.

An identical chassis is fitted in the 804 console, although a larger speaker is used with it, and this *Service Sheet* covers both models, but it was prepared from an 801 table model.

Release date and original prices: August, 1938 (for both models); 801, £10 10s.; 804 console, £14 3s. 6d.

### CIRCUIT DESCRIPTION

Aerial input, fed via isolating condensers **C1** and **C2**, is developed across **L1**, **R1**. On MW and LW, when **S1** is closed, it is then developed across condensers **C3**, **C4**, which form a potential divider across the aerial circuit, that fraction which appears across **C4** being bottom coupled to the aerial tuning coils **L3** (MW) and **L4** (LW). These form single-tuned circuits with **C32**.

On SW, **S1** opens, and input is then fed via **C3** and **C5** to single-tuned circuit **L2**, **C32**. The effect of **C5** on MW and LW is negligible, and is in parallel with **C4**.

**R3** is connected across the contacts of **S3** in order to prevent **V1** tetrode control grid from becoming free when the gram button is pressed, leaving **S3** open. **L1**, **R1** form a modulation hum suppression circuit across the aerial.

First valve (**V1**, American 6A8G) is a

pedance of the trackers **C37** (via **C9**, **S8** and **S9**, SW); **C38** and **C37** (via **S9**, MW); and **C39** and **C37** (via **L8**, **C9** and **S8**, LW), the trackers being common to grid and anode circuits.

**R8** is actually the control grid resistance for **V1** oscillator section, and is returned to the cathode, but as it is connected via switches, a high resistance **R5** is shunted directly across the control grid circuit to tie the grid down to chassis for gram operation, when **S5-S7** are open. **C11** returns the screen grid to chassis, but a small condenser **C10** is connected between that electrode and chassis.

Second valve (**V2**, American 6U7G) is a variable- $\mu$  RF pentode operating as intermediate frequency amplifier with tuned-primary, tuned-secondary transformer couplings **C40**, **L10**, **L11**, **C41** and **C42**, **L12**, **L13**, **C43**.

Intermediate frequency 465 kc/s.

Diode second detector is part of double diode triode valve (**V3**, American

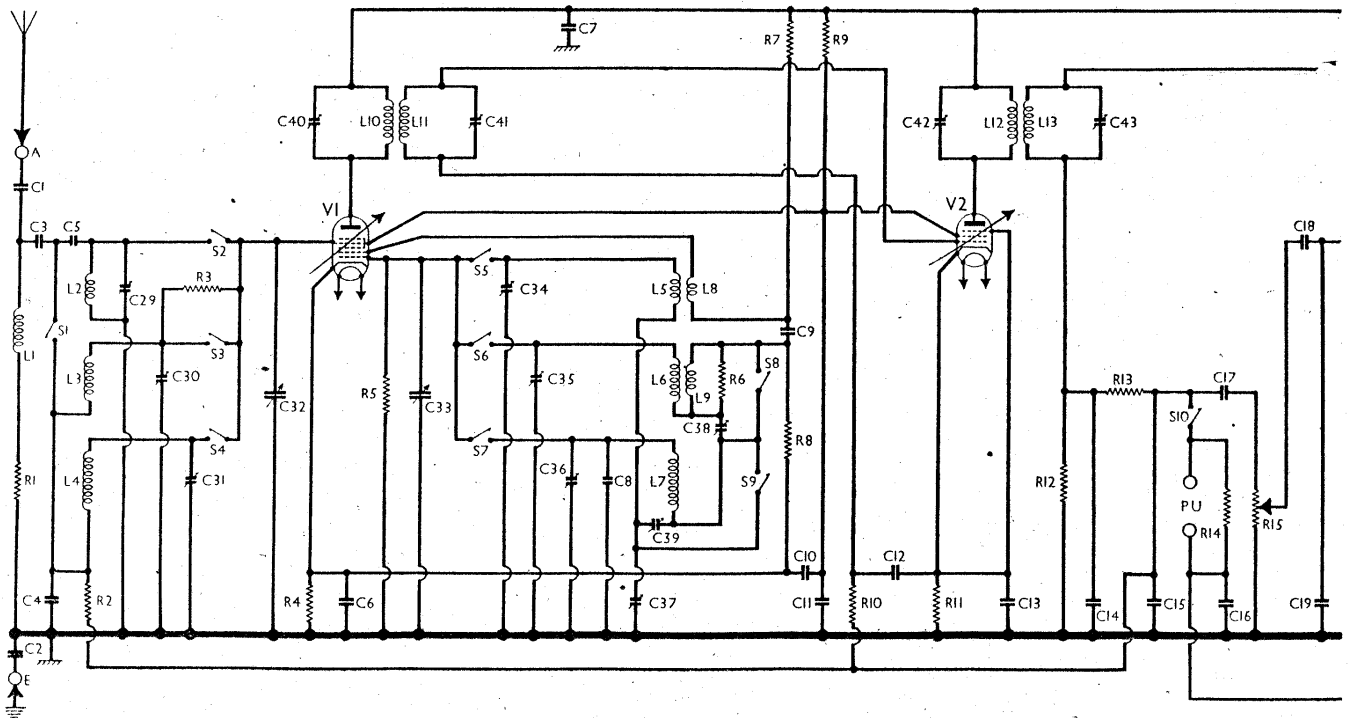

heptode operating as frequency changer with electron coupling. Oscillator grid coils **L5** (SW), **L6** (MW) and **L7** (LW) are tuned by **C33**. Parallel trimming by **C34** (SW), **C35** (MW) and **C8**, **C36** (LW); series tracking by **C37** (SW), **C38** (MW) and **C39** (LW). Inductive reaction coupling by **L8** (SW) and, via **C9**, **L9** (MW); and capacitive coupling across the im-

Circuit diagram of the Ferguson 801 AC/DC superhet. **V1-V3** heaters and the scale lamps are shunted by **R29**, and **V5** heater by **R30**, as **V4** requires a greater heater current than the other valves in the chain. The leads to the heater ballast resistance are colour coded. This circuit applies equally to the 804 console.

6Q7G), both diode anodes being strapped together. Audio frequency component in rectified output is developed across load resistance **R12** and passed via **IF** stopper **R13**, AF coupling condenser **C17**, manual volume control **R15** and further AF coupling condenser **C18**, to CG of triode section, which operates as AF amplifier. IF filtering by **C14**, **R13**, **C15** in diode circuit, **C19** in grid circuit and **C21** in anode circuit. Variable tone control by **G22**, **R19** in anode circuit. Provision for connection of pick-up across **C17**, **R15** via **S10**, the sockets being shunted by **R14**.

DC potential developed across **R12** is tapped off at the junction of **R13** and **C17** and fed back through decoupling circuits as GB to FC (except on SW) and IF valves, giving automatic volume control.

Resistance-capacity coupling by **R18**, **C23** and **R20** between **V3** triode and beam tetrode output valve (**V4**, American 6V6G). Fixed tone correction by **R21**, **C24** in anode circuit. Provision for connection of high impedance external speaker, also in anode circuit.

When the receiver is used with AC mains, HT current is supplied by IHC half-wave rectifying valve (**V5**, American 25Z6G) which, with DC mains, operates as a low resistance. This valve is of the voltage-doubler type, but the two halves are connected in parallel, a surge limiting resistance **R26**, **R27** being included in each anode lead. Smoothing is

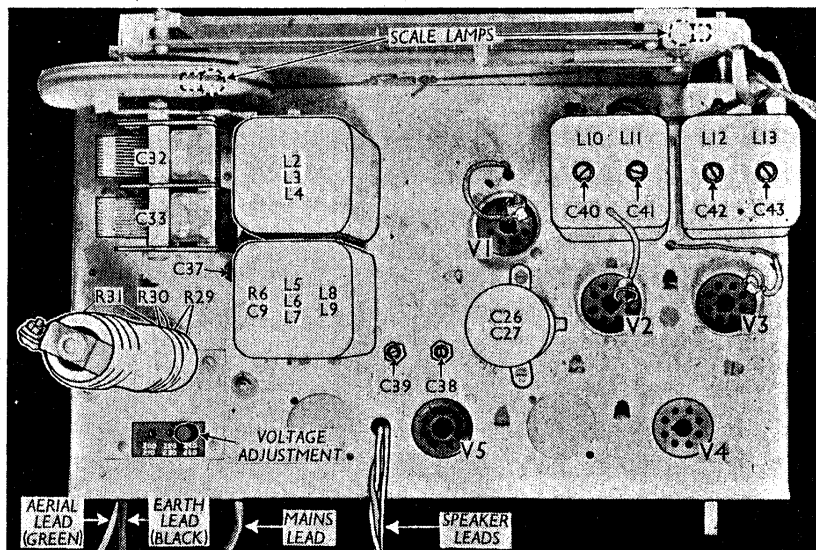

Plan view of the chassis. The various sections of the heater ballast resistance unit are indicated. The colour coding is shown in the circuit diagram below.

effected by an iron-cored choke **L15** and dry electrolytic condensers **C26**, **C27**. Valve heaters, together with scale lamps and ballast resistance **R31**, are con-

nected in series directly across the mains input. Since **V4** heater current is 0.45 A, however, and that of the remaining valves is 0.3 A, the surplus 0.15 A is bypassed by shunt resistances: **R30** shunts **V5** heater, while **R29** shunts **V1-V3** and the scale lamps. The scale lamps are again shunted by **R28** in order to lower their current to something below 0.3 A.

GB potential for **V3** triode is obtained from the drop along **R25**, through which HT current flows to chassis. When the receiver is switched to gram this potential is also applied via **R14**, **S10** and the AVC line to **V1** and **V2**.

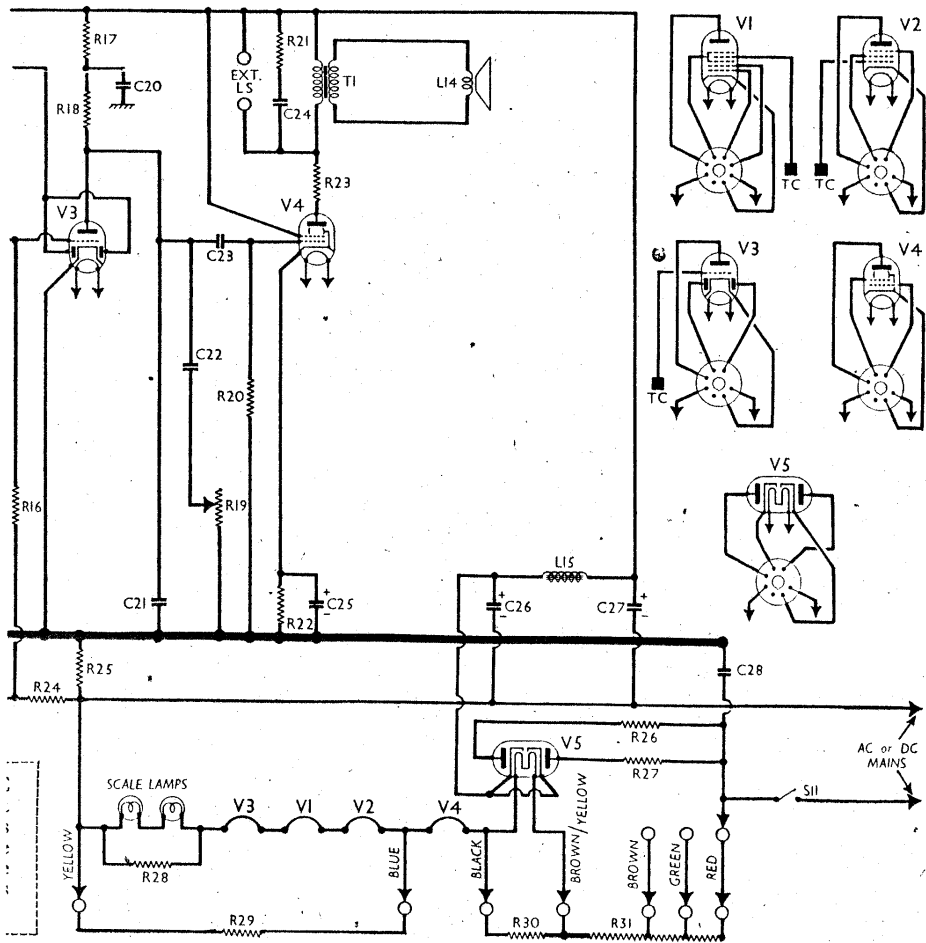

COMPONENTS AND VALUES

RESISTANCES		Values (ohms)
R1	Anti-modulation choke damping ...	10,000
R2	V1 tetrode CG decoupling ...	500,000
R3	V1 tetrode CG resistance ...	3,000,000
R4	V1 fixed GB resistance ...	150
R5	V1 osc. CG resistance ...	500,000
R6	Osc. circuit MW reaction damping ...	2,500
R7	V1 osc. anode HT feed resistance ...	25,000
R8	V1 osc. CG resistance ...	50,000
R9	V1, V2 SG's HT feed resistance ...	25,000
R10	V2 CG decoupling ...	500,000
R11	V2 fixed GB resistance ...	300
R12	V3 diodes load resistance ...	500,000
R13	IF stopper ...	25,000
R14	Gramophone PU shunt ...	25,000
R15	Manual volume control ...	500,000
R16	V3 triode CG resistance ...	500,000
R17	V3 triode anode HT feed ...	50,000
R18	V3 triode anode load ...	250,000
R19	Variable tone control ...	100,000
R20	V4 CG resistance ...	500,000
R21	Part fixed tone corrector ...	10,000
R22	V4 GB resistance ...	300
R23	V4 anode stopper ...	100
R24	V3 triode CG decoupling ...	250,000
R25	V3 triode GB resistance ...	35
R26	V5 anode surge limiting resistances ...	100
R27	V5 anode surge limiting resistances ...	100
R28	Scale lamp shunt ...	90
R29	V1-V3 heater circuit shunt ...	193
R30	V5 heater shunt ...	166
R31	Heater circuit ballast ...	422*

\* Tapped at 332 Ω + 45 Ω + 45 Ω from V5 heater end.

CONDENSERS		Values ( $\mu$ F)
C1	Aerial series condenser ...	0-0005
C2	Earth isolating condenser ...	0-1
C3	Aerial circuit MW and LW	0-0001
C4	coupling condensers ...	0-004
C5	Aerial SW coupling condenser ...	0-00002
C6	V1 cathode by-pass ...	0-1
C7	HT circuit RF by-pass ...	0-25
C8	Osc. circuit LW fixed trimmer ...	0-00006
C9	V1 osc. anode coupling ...	0-00025
C10	V1, V2 SG's RF by-pass ...	0-1
C11	V1, V2 SG's decoupling ...	0-1
C12	V2 CG decoupling ...	0-1
C13	V2 cathode by-pass ...	0-00025
C14	IF by-pass condensers ...	0-00025
C15	V3 triode and PU feed decoupling ...	0-25
C16	AF coupling condensers to V3 triode ...	0-02
C17	V3 triode ...	0-02
C18	IF by-pass ...	0-0001
C19	V3 anode RF by-pass ...	0-1
C20	IF by-pass ...	0-00025
C21	Part of variable tone control	0-01
C22	V3 triode to V4 AF coupling ...	0-01
C23	Part fixed tone corrector	0-01
C24	V4 cathode by-pass ...	5-0
C25*	HT smoothing condensers	16-0
C26*		16-0
C27*		16-0
C28	Mains RF by-pass ...	0-1
C29†	Aerial circ. SW trimmer ...	—
C30†	Aerial circ. MW trimmer ...	—
C31†	Aerial circuit LW trimmer ...	—
C32†	Aerial circuit tuning ...	—
C33†	Oscillator circuit tuning ...	—
C34†	Osc. circuit SW trimmer ...	—
C35†	Osc. circuit MW trimmer ...	—
C36†	Osc. circuit LW trimmer ...	—
C37†	Osc. circuit SW tracker ...	—
C38†	Osc. circuit MW tracker ...	—
C39†	Osc. circuit LW tracker ...	—
C40†	1st IF trans. pri. trimmer ...	—
C41†	1st IF trans. sec. trimmer ...	—
C42†	2nd IF trans. pri. trimmer ...	—
C43†	2nd IF trans. sec. trimmer ...	—

\* Electrolytic. † Variable. ‡ Pre-set.

OTHER COMPONENTS		Approx. Values (ohms)
L1	Aerial anti-modulation choke ...	20-0
L2	Aerial SW tuning coil ...	0-1
L3	Aerial MW tuning coil ...	3-0
L4	Aerial LW tuning coil ...	17-0
L5	Osc. SW tuning coil ...	0-1
L6	Osc. MW tuning coil ...	3-0
L7	Osc. LW tuning coil ...	5-9
L8	SW reaction coil ...	0-5
L9	MW reaction coil ...	1-0
L10	1st IF trans. { Pri. ...	9-0
L11	{ Sec. ...	11-0
L12	2nd IF trans. { Pri. ...	12-0
L13	{ Sec. ...	9-0
L14	Speaker speech coil ...	2-0
L15	HT smoothing choke ...	230-0
T1	Speaker input { Pri. ...	500-0
	{ Sec. ...	0-5
S1-S9	Waveband switches ...	—
S10	Gram. pick-up switch ...	—
S11	Mains switch, ganged R15 ...	—

**VALVE ANALYSIS**

Valve voltages and currents in the table (next column) are those quoted in the

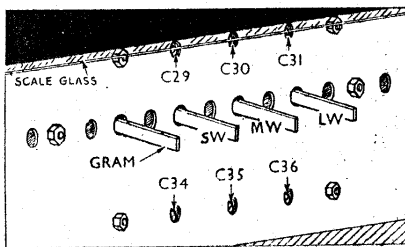

Sketch showing the positions of the trimmers as seen from the front of the chassis.

makers' manual. They represent values to be expected in the average chassis when it is connected to AC mains of 240 V, 50 c/s, with the MW button depressed, the gang turned to maximum capacity, the volume control turned to minimum and the aerial and earth leads joined together.

Voltages were measured with a meter having a resistance of 1,000 ohms per volt, chassis being the negative connection.

If the set should become unstable when V2 anode and screen currents are being measured, it can be stabilised by connecting a non-inductive condenser of about 0.1  $\mu$ F from the electrode concerned to chassis.

Valve	Anode Voltage (V)	Anode Current (mA)	Screen Voltage (V)	Screen Current (mA)
V1 6A8G	{ 240 Oscillator, 138	{ 5-2 3-1	90	3-4
V2 6U7G	240	7-2	90	2-1
V3 6Q7G	115	0-4	—	—
V4 6V6G	220	35-0	240	3-2
V5 25Z6G	340†	—	—	—

† Cathodes to chassis, DC.

**DISMANTLING THE SET**

**Removing Chassis.**—Remove the four press-button knobs (pull off) and the two rotary control knobs (pull off) from the front of the cabinet; remove the four set-screws (with metal washers and lock-washers) holding the chassis to the bottom of the cabinet. The chassis may now be withdrawn to the extent of the speaker leads, which is sufficient for normal purposes. To free the chassis entirely, unsolder from the connecting panel on the speaker transformer the three leads connecting it to chassis.

When replacing, connect the speaker leads as follows, numbering the tags on the transformer from left to right:

- 1, no external connection;
- 2, red lead from chassis (and brown lead from smoothing choke);
- 3, blue lead from chassis;
- 4, red lead with white tracer from chassis (and green lead from smoothing choke).

The press-button knobs should be fitted in the following sequence, numbering the plungers from left to right when viewed from the front of the cabinet:

- 1, gram; 2, SW; 3, MW; 4, LW.
- Take care that the buttons do not foul the escutcheon as they are depressed, and do not omit to replace the felt washers between the rotary control knobs and the front of the cabinet.

**Removing Speaker.**—Unsolder from the tags on the transformer the three leads connecting them to chassis, and remove the four nuts holding the rim of the speaker to the sub-baffle.

When replacing, see that the transformer is at the top, and connect the leads as previously described.

**GENERAL NOTES**

**Switches.**—All the switches, with the exception of S11, the mains switch, are of the press-button type, and are contained in a single double-sided unit mounted inside the front of the chassis.

The switch unit is indicated in our under-chassis view, but for identification

of the individual switches, diagrams showing the two sides of the unit are given below. The upper diagram of the two shows the switches as seen when looking from the rear of the underside of the chassis, while the lower one shows the switches on the unit which are normally hidden from view by the chassis deck.

To examine these, the whole switch unit must be removed. It can be withdrawn and turned sufficiently to expose the hidden side without disconnecting all the leads if the six screws and nuts (with lock-washers) holding it and the two banks of trimmers (one above and one below the switch unit) are removed and one end of C5 is unsoldered. It should be eased out gently, after depressing all the press-button plungers together, to avoid straining and breaking the connecting wires.

The table below shows which of the switches are open and which are closed when any button, shown in the left-hand column, is depressed.

**SWITCH TABLE AND DIAGRAMS**

Button	Closed	Open
LW	S1, S4, S7, S8	S2, S3, S5, S6, S9, S10
MW	S1, S3, S6, S9	S2, S4, S5, S7, S8, S10
SW	S2, S5, S8, S9	S1, S3, S4, S6, S7, S10
Gram.	S1, S8, S9, S10	S2, S3, S4, S5, S6, S7

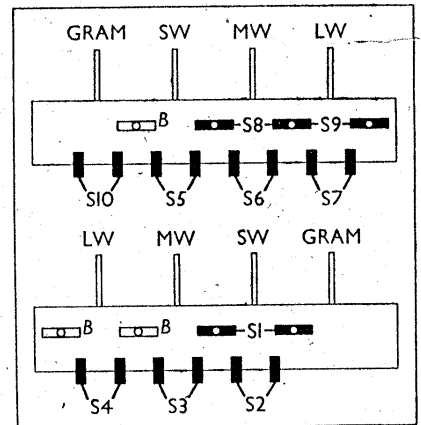

Diagrams of both sides of the switch unit. The upper one shows the switches seen from the underside of the chassis, while the lower one shows those on the side facing the chassis deck.

S11 is the QMB mains switch, ganged with the volume control R15.

**Coils.**—L1 is beneath the chassis, close to the aerial lead entry point. L2-L4; L5-L9 and the IF transformers L10, L11 and L12, L13 are in four screened units on the chassis deck. The second unit also contains R6, C9, while the IF units contain their associated trimmers.

**Scale Lamps.**—These are two National Union miniature bayonet cap types, marked N51.

**External Speaker.**—Two sockets are provided at the rear of the chassis for a high impedance (10,000  $\Omega$ ) speaker.

Under - chassis view. The position of the press-button switch unit is indicated. The two sides of the unit are shown in detail in the diagrams in col. 3. The RF and oscillator trimmers are seen just above the unit, but they also are shown in detail in a separate sketch (col. 1), as seen from the front of the chassis, together with the press-button plungers.

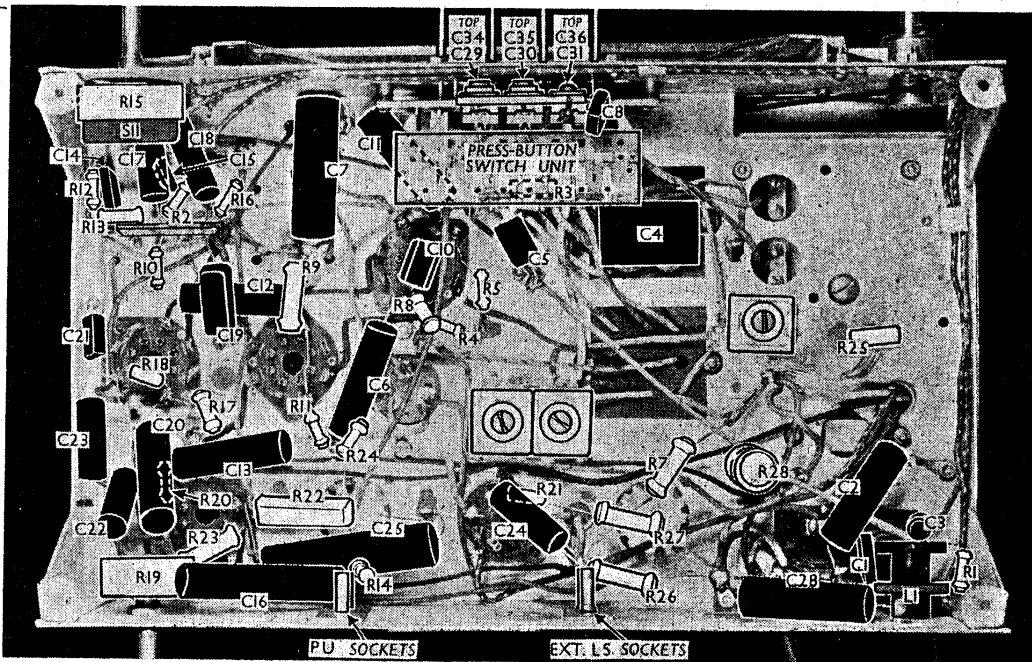

As these are connected directly to the HT circuit, they are "live" to the mains, so that the connecting leads should be well insulated. A low impedance speaker (about 5  $\Omega$ ) could be connected to the speech coil tags on the transformer.

**Condenser C25.**—This is a Plessey tubular electrolytic, in a cardboard container, rated at 5  $\mu\text{F}$ , 35 V working, 45 V surge.

**Condensers C26, C27.**—These are two TCC dry electrolytics in a single metal tubular container mounted vertically on the chassis deck. They are both rated at 16  $\mu\text{F}$ , 350 V working, 400 V surge. The two positive tags are marked with red paint; the plain tag is the common negative connection.

**Pre-set Condensers.**—The six RF and oscillator trimmers are arranged in two banks of three and mounted on the inside of the front chassis member. Their adjustments are reached through holes in the chassis stamping, so that the chassis must be removed from the cabinet for alignment. When the chassis is standing on its base, in the upper bank are the aerial trimmers, and in the lower bank the oscillator trimmers. Between the two banks are the press-button plungers, and the sequence of the trimmers is the same as that of the plungers in each case: SW, MW and LW, reading from left to right when viewed from the front. The adjustments are indicated in our under-chassis view, but their positions are shown more clearly in the diagram in col. 1. The three trackers **C37, C38, C39** are mounted beneath the chassis, but their adjustments project through the chassis deck and are reached from above.

**Mains Resistance Unit.**—**R29, R30** and **R31** are wound on a single vitreous enamelled unit mounted on the chassis deck. The first three sections from the top downwards comprise **R31** with its mains voltage adjustments, the fourth is **R30**, and the bottom one, separated from

**R30** by a blank section, is **R29**, which is insulated from the others. The scale lamp shunt resistance **R28** is in a separate vitreous enamelled unit beneath the chassis.

The connections to the main unit are indicated in the circuit diagram, where the colour coding of the leads is given. The brown lead is the voltage adjustment tapping for the 200-210 V position, the green one for the 220-230 V position, and the red one for 240-250 V position. The actual adjustment is carried out by means of an insulated knurled screw on a marked panel just beside the unit.

**Chassis Divergencies.**—**C8, C28, R23** and **R8** are not shown in the makers' diagram. A 25  $\mu\text{F}$  electrolytic by-pass condenser is shown connected across **R25**, the auto GB resistance, in the makers' diagram, as is also a second 0.00025  $\mu\text{F}$  IF by-pass condenser in addition to **C21** in **V3** triode anode circuit, but these were not present in our sample.

#### CIRCUIT ALIGNMENT

**IF Stages.**—Remove the grid (top cap) connection of **V1**, and connect a 500,000  $\Omega$  resistor between the connection and the cap. Connect signal generator between the cap (via a 0.00025  $\mu\text{F}$  condenser) and the earth lead. Switch set to MW, and turn gang and volume control to maximum.

Feed in a 465 kc/s signal, and adjust **C43, C42, C41** and **C40** for maximum output. Re-check, then remove the 500,000  $\Omega$  resistor and replace top cap.

**RF and Oscillator Stages.**—With the gang at maximum, pointer should be at the right hand terminations of the horizontal scales. Connect signal generator to **A** and **E** leads, via a suitable dummy aerial. Turn volume control to maximum.

**SW.**—Since the SW tracker is in series with the MW and LW trackers it is essential to align the SW band first.

Switch set to SW, tune to 15 Mc/s on scale and feed in a 15 Mc/s (20 m) signal. Adjust **C34** for maximum output, using the peak involving the lesser trimmer capacity. Now adjust **C29** for maximum.

Feed in a 6 Mc/s (50 m) signal, tune it in, and adjust **C37** for maximum output, while rocking the gang for optimum results. Return to 15 Mc/s and re-check **C29** and **C34**. Repeat until no further improvement results.

**MW.**—Switch set to MW and tune to 250 m on scale. Feed in a 250 m (1,200 kc/s) signal, and adjust **C35**, then **C30** for maximum output. Feed in a 520 m (580 kc/s) signal, tune it in, and adjust **C38** for maximum output, while rocking the gang for optimum results. Return to 250 m and re-check **C35** and **C30**. Repeat until no further improvement results.

**LW.**—Switch set to LW, and tune to maximum output. Feed in a 520 m (240 kc/s) signal, and adjust **C36**, then **C31**, for maximum output. Feed in a 2,000 m (150 kc/s) signal, tune it in, and adjust **C39** for maximum output, while rocking the gang for optimum results. Return to 1,250 m and re-check **C36** and **C31**. Repeat until no further improvement results.

#### CORRECTION

IN a notice published at the end of *Service Sheet 631*, in the last issue of *The Trader*, the price of *Service Sheet* reprints was given as 7/6 per dozen. This should have read 7/- per dozen, and we shall be glad if dealers will kindly make the necessary correction.